

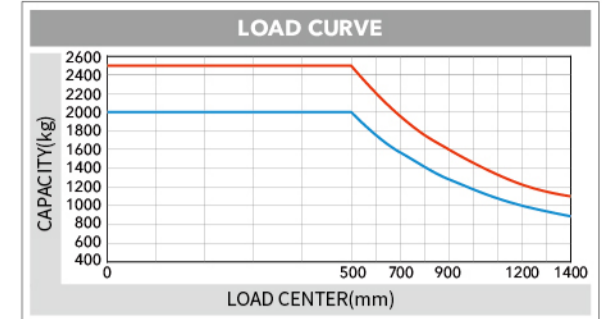

Manufacturer's Data and Design Characteristics

Characteristics		HELI	
1.01	Manufacturer	HELI	
1.02	Model	CQD20	CQD25
1.03	Configuration number	GC2RLi	GC2RLi
1.04	Rated capacity	Q	kg
1.05	Load center distance	c	mm
1.06	Power mode	Battery	
1.07	Driving mode	Stand-on	
1.08	Front overhang	x	mm
1.09	Wheelbase	y	mm
Weight			
2.01	Total weight (with/without battery)	kg	3200/2450 3230/2480
2.02	Axle load ,unladen,front/rear (fork advanced)	kg	1620/1580 1640/1590
2.03	Axle load ,unladen,front/rear (fork retracted)	kg	2170/1030 2200/1030
2.04	Axle load ,laden,front/rear (fork advanced)	kg	680/4520 560/5170
2.05	Axle load ,laden,front/rear (fork retracted)	kg	2100/3100 2410/3320
Tyres			
3.01	Tyre type	Polyurethane	
3.02	Tyre size,front	ø330x114	
3.03	Tyre size,rear	ø285x100	
3.04	Wheels,number front/rear (x=driven wheels)	1x/2/2	
3.05	Tread , rear	b11	mm
Dimensions			
4.01	Fork tilt angle (forward/backward)	α/β	°
4.02	Height (mast lowered)	h1	mm
4.03	Free lifting height	h2	mm
4.04	Lifting height (standard)	h3	mm
4.05	Max. height,extended (with backrest)	h4	mm
4.06	ddedite	h6	mm
4.07	Overall length (with fork)	l1	mm
4.08	Overall length (without fork)	l2	mm
4.09	Overall width	b1	mm
4.10	Fork size:thickness x width x length	s/e/l	mm
4.11	Fork carriage,according to ISO2328	class II	
4.12	Distance between fork-arms, Max./Min.	b5	mm
4.13	Fork sideshifting	±55	
4.14	Distance between support arms	b4	mm
4.15	Ground clearance (laden,between mast)	m1	mm
4.16	Right angle stacking aisle width for pallet 1000 x1200mm crossways	Ast	mm
4.17	Right angle stacking aisle width for pallet 800 x1200mm lengthways	Ast	mm
4.18	Min. outside turning radius	Wa	mm
Performance Data			
5.01	Travel speed (laden/unladen)	km/h	10/11.5 10/11.5
5.02	Lift speed (laden/unladen)	m/s	0.3/0.45 0.27/0.45
5.03	Lowering speed (laden/unladen)	m/s	0.5/0.45 0.5/0.45
5.04	Reach speed (laden/unladen)	m/s	0.1/0.1 0.1/0.1
5.05	Max. gradeability (laden/unladen)	%	10/15 10/15
Battery			
6.01	Battery voltage/Capacity	V/Ah	48/404 48/404
6.02	Battery weight (Min./Max.)	kg	750 750
6.03	Battery box dimension	mm	1035x352x824 1035x352x824
Motor and controller			
7.01	Driving motor powering (S2-60min)	kW	5
7.02	Lifting motor powering (S3-15%)	kW	10
7.03	Driving motor controlling mode	MOSTET/AC	
7.04	Lifting motor controlling mode	MOSTET/AC	
7.05	Steering motor controlling mode	MOSTET/AC	
Addition data			
8.01	Transmission box	HELI special transmission box	
8.02	Service brake/Parking brake	electromagnetic/electromagnetic	

NOTE: Detailed information about battery,please contact our salesmen or engineer.

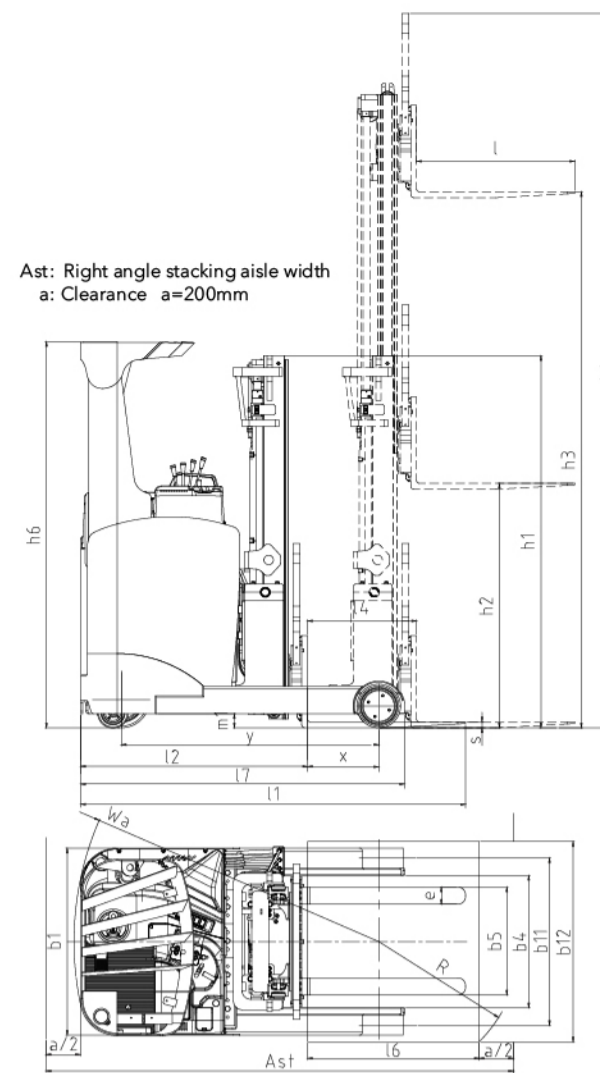

2 t 2.5 t

Note: The vertical axis stands for load capacity and the horizontal axis stands for load center which is calculated from the front surface of the forks to the gravity of the standard load. the standard load means a cubic with 1000mm edge length. When mast is tilted forward, using non-standard forks or loading large goods, the load capacity will be reduced. The load capacity of standard mast at different load center can be known from this load chart.

Configuration number	Configuration
GC2RLi	Manually operated valve
	Mechanical handle control hydraulic functions
	ZAPI travelling motor controller
	ZAPI lifting motor controller
	ZAPI steering motor controller
	Lithium battery

Wide View Standard Mast

Mast model	Max.lifting height (mm)	Load capacity (lode center 500mm)(kg)		Height (mast lowered) (mm)		Free lift(with backrest) (mm)		Service weight (kg)		Fork tilt angle α/β (°)
		CQD20	CQD25	CQD20	CQD25	CQD20	CQD25	CQD20	CQD25	
M250	2500	2000	2500	2024	2024	80	80	3120	3150	2°/4°
M270	2700	2000	2500	2124	2124	80	80	3140	3170	2°/4°
M300	3000	2000	2500	2274	2274	80	80	3170	3200	2°/4°
M330	3300	2000	2500	2424	2424	80	80	3200	3230	2°/4°
M360	3600	2000	2500	2574	2574	80	80	3230	3260	2°/4°
M400	4000	2000	2500	2774	2774	80	80	3270	3300	2°/4°
M430	4300	1900	2400	2924	2924	80	80	3300	3330	2°/4°
M460	4600	1900	2400	3074	3074	80	80	3330	3360	2°/4°
M500	5000	1800	2300	3274	3274	80	80	3413	3443	2°/4°
M540	5400	1500	2000	3474	3474	80	80	3453	3483	2°/4°

Wide View Full Free 3-Stage Mast

Mast model	Max.lifting height (mm)	Load capacity (lode center 500mm)(kg)		Height (mast lowered) (mm)		Free lift(with backrest) (mm)		Service weight (kg)		Fork tilt angle α/β (°)
		CQD20	CQD25	CQD20	CQD25	CQD20	CQD25	CQD20	CQD25	
ZSM360	3600	2000	2500	2005	2005	980	980	3318	3348	2°/4°
ZSM400	4000	2000	2500	2138	2138	1110	1110	3355	3385	2°/4°
ZSM430	4300	1900	2400	2238	2238	1210	1210	3384	3414	2°/4°
ZSM460	4600	1900	2400	2338	2338	1310	1310	3412	3442	2°/4°
ZSM480	4800	1800	2300	2405	2405	1380	1380	3432	3462	2°/4°
ZSM540	5400	1500	2000	2605	2605	1580	1580	3470	3500	2°/4°
ZSM570	5700	1450	1950	2705	2705	1680	1680	3540	3570	2°/4°
ZSM600	6000	1400	1900	2805	2805	1780	1780	3569	3599	2°/4°
ZSM650	6500	1300	1800	2972	2972	1947	1947	3619	3649	2°/4°
ZSM740	7400	1000	1500	3272	3272	2247	2247	3719	3749	2°/4°

HELI

HELI

Reliable special designed instrument

- Information display
- Low voltage indicator
- Fault indicator
- Hour meter
- Enter
- Performance selecting button (up)
- Performance selecting button (down)
- Battery electric quantity indicator
- For spare
- Handbrake state indicator
- Safety switch indicator
- Exit
- Value setting button (decrease)
- Value setting button (increase)

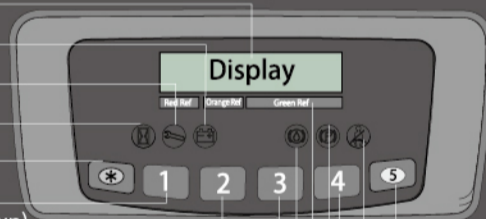

The reliable special instrument gives a complete display of the vital information, like operation status, fault detection, etc. It ensures the operator predominate the vehicle status more intuitive and convenient.

ZAPI intelligent type meter (for GC2R model)



RENEWABLE ENERGY TECHNOLOGIES

With the use of AC controlling renewable energy technologies, the forklift is more energy-saving and the working hour of the battery is extended by 15%.

15%

LIION 2-2.5t

G2 SERIES LITHIUM BATTERY POWERED REACH TRUCK (STAND-ON TYPE)



ANHUI HELI CO., LTD.
Add / No.668, FangXing Road, Hefei, China
Fax / +86-551-63639966

Tel / +86-551-63639068(America); 63639258(Europe);
63639358(Asia); 63662105(Africa & Middle East);
63639530(Key Accounts Division); 63662105(Wheel loader)

CHINA NO.202001015 P0601 P1111

www.heliforklift.net

* Our products are subject to improvements and changes without notice.

Three phase AC type motor technology

- Three phase AC type motor control on travelling, lifting and steering
- Good acceleration
- Fast and sensitive respond on travel direction shifting
- Free from maintenance motor without carbon brush having long service life and low maintenance cost, energy regenerating during deceleration extending operation hours

Newly designed hydraulic system

- Newly designed hydraulic system with high working efficiency
- High power lifting motor
- MOSTET lifting speed governing electric controller
- New type low noisy gear pump, high efficiency and long life

Optimized intelligent design

- CAN bus technology
- Parking brake on slope
- Operation sequence protection
- Travelling speed control
- Lifting speed control
- Electric controller self protection
- Dead-man footswitch traction interlock

Advanced EPS electric powered steering

- EPS electric powered steering offering easy, flexible, high efficient and mute operation
- Steering motor controller
- Automatic centering function
- Automatic limit on speed and accelerated speed when steering

Easy operated thumb switch

- To control travelling functions
- Clear operating units

Six independent braking systems

- Automatic braking when accelerator lever is released
- Emergency brake activated by releasing foot switch
- Parking brake activated by pressing button on the panel
- Automatic hold-on brake
- Parking brake activated by hydraulic control lever
- Emergency isolator

Wide view mast

- Good view when loaded
- Integral sideshifter
- High residual load capacity at high lift height
- Buffering on lifting limit
- Buffering on mast moving forward and backward limit
- Fork tilt



Environment Friendly

- Zero emission
- Low noise
- Free of heavy metals
- No corrosion
- No acid mist volatilization

High Safety

- According to the characteristics of industrial vehicles, it achieves safety protection design which includes lithium battery materials, battery core type, pack technique and system power management
- "Multiple node safety closed circuit protection" realizing truck real time closed circuit protection in variable conditions
- "Lock affirming" function during charging avoiding "hot connecting and disconnecting" operation effectively
- "Whole system emergency button" to disconnect the truck control system and bms power quickly ensuring truck safety

Suitable for working in both high and low environment

- Lithium battery is better than lead-acid battery when working between -25°C and 55°C

Maintenance Free

- Unnecessary of fluid adding and dust proofing
- Daily maintenance free
- Manual maintenance free

Long Service Life

- Over 75% capacity reserved after 4000 shifts operation
- Longer service life than lead-acid battery in equal working condition
- 5 years or ten thousand hours quality guarantee for high performance lithium battery assembly

High Efficiency and Energy Saving

- 2 hours charging meet 6-8 hours working demand
- High-energy density, self discharging rate lower than 1% per month
- 95% energy conversion rate, superior charging and discharging performance
- Flexible to charge, easy to operate, no impact on battery life
- Unnecessary to change battery, cost saving



HELI smart fleet management system (optional)

- Vehicle positioning
- Remote diagnosis
- Remote monitoring
- Maintenance reminder
- Battery management
- Statistical form
- Vehicle management
- Identification recognition (optional)
- Weight management (optional)
- Collision management (optional)



Standard Equipment

- AC travelling motor
- AC Lifting motor
- AC steering motor
- Electrical brake
- DC/DC converter
- Low noisy gear pump
- Control valve(four throw)
- 3300mm two-stage mast
- Integral sideshifter
- Standard fork
- Backrest
- Polyurethane tyre
- LED meter
- Front working light
- Vertical battery change
- Warning light

Optional Equipment

- Three-stage full free lift mast
- Two-stage mast(other lifting height)
- Fork with other length
- Fork extension
- Monitoring system
- Other battery
- Battery charger
- Alternative colour schemes